

CA-Roof



- For commercial and industrial applications in factories, hospitals, discotheques, offices, theatres, condominiums, gyms, restaurants, etc..
- 6 models, with deliveries up to 1,600 m³/h.
- Certified by IMQ performance
- In-line centrifugal extractor fan in painted, galvanised steel with ABS hood.

- Asynchronous, external rotor type motor with turbine fan.
- Suitable for external roof mounting.
- IPX4 splash protection.
- Operating temperatures from -20° to +55°

Wiring diagrams shown on page XXXI.

LONG LIFE

30.000 h



- ① Installation for air extraction centralized system
- ② Installation with protection grille
- ③ Installation with backdraught shutter



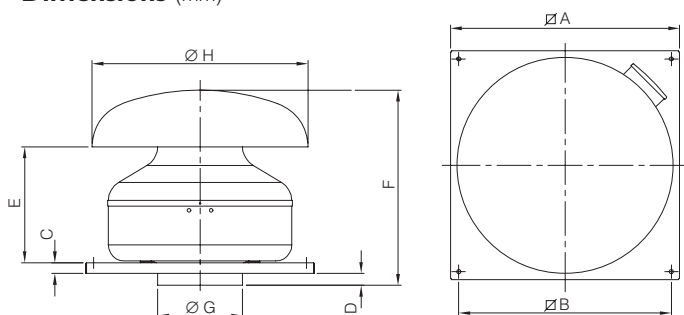



Dimensions (mm)



	Ø A	Ø B	C	D	E	F	Ø G	Ø H
CA 125 RF	334	280	20	2	193	290	122	300
CA 150 RF	424	370	20	17	198	340	147	400
CA 160 RF	424	370	20	22	214	361	157	400
CA 200 RF	424	370	20	17	203	345	197	534
CA 250 RF	489	435	20	27	193	376	247	534
CA 315 RF	489	435	20	21	226	403	312	534

Product	Code	V	Hz	W	A	Rpm	Delivery		P max		Lp dB(A) 3 m	Approvals	kg	Insulation	Protection	°C max	
							m³/h	l/s	mm H ₂ O	Pa							
CA 125 RF	16013	220-240	50	75	0.34	2300	350	97	32	314	54		4.6		cl.I	X4	55
CA 150 RF	16023	220-240	50	80	0.34	2370	450	125	27	265	56.5		7		cl.I	X4	55
CA 160 RF	16073	220-240	50	150	0.68	2650	750	208	60	588	64		8.8		cl.I	X4	55
CA 200 RF	16043	220-240	50	160	0.69	2700	850	236	55	539	63		8		cl.I	X4	55
CA 250 RF	16053	220-240	50	180	0.80	2430	1180	327.5	58	568	61.5		9.9		cl.I	X4	55
CA 315 RF	16063	220-240	50	250	1.1	2480	1600	444.5	75	735	64.5		11		cl.I	X4	50

Accessories (description and data on pages 81/93).

Model		Code	Products
	C 1.5 (electronic speed controller)	12966	for all products (except code 16053 -16063)
	C 2.5 (electronic speed controller)	12967	16053 -16063
	SCNRB (electronic speed controller)	12971	16013 -16023 -16073 -16043 -16053
	SCB kit (flush mounting conversion)	22481	12966
	CARF-C 125 (sub-frame)	22543	16013
	CARF-C 150/160/200 (sub-frame)	22544	16023 -16073 -16043
	CARF-C 250/315 (sub-frame)	22545	16053 -16063
	CA-FU 125 (pipe clamps)	22668	16013
	CA-FU 150 (pipe clamps)	22669	16023
	CA-FU 160 (pipe clamps)	22666	16073
	CA-FU 200 (pipe clamps)	22671	16043
	CA-FU 250 (pipe clamps)	22672	16053
	CA-FU 315 (pipe clamps)	22673	16063
	Lineo-S 125 (backdraught shutter)	22556	16013
	Lineo-S 150 (backdraught shutter)	22562	16023
	Lineo-S 160 (backdraught shutter)	22563	16073
	Lineo-S 200 (backdraught shutter)	22566	16043
	Lineo-S 250 (backdraught shutter)	22571	16053
	Lineo-S 315 (backdraught shutter)	22576	16036
	CA-G 125 (intake protection grille)	22755	16013
	CA-G 150 (intake protection grille)	22760	16023
	CA-G 160 (intake protection grille)	22762	16073
	CA-G 200 (intake protection grille)	22765	16043
	CA-G 250 (intake protection grille)	22770	16053
	CA-G 315 (intake protection grille)	22775	16063

Pressure/performance curves

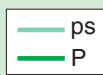
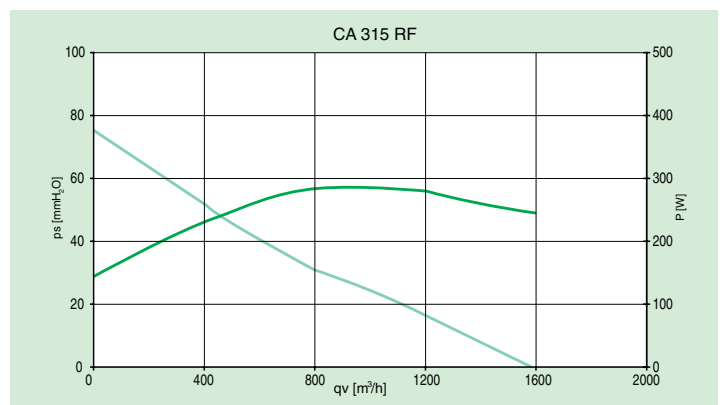
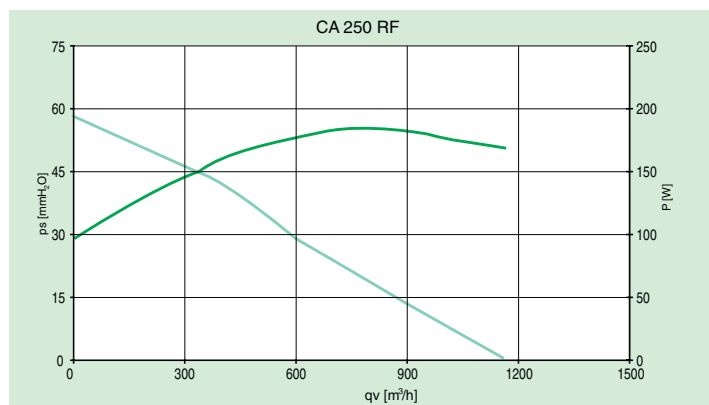
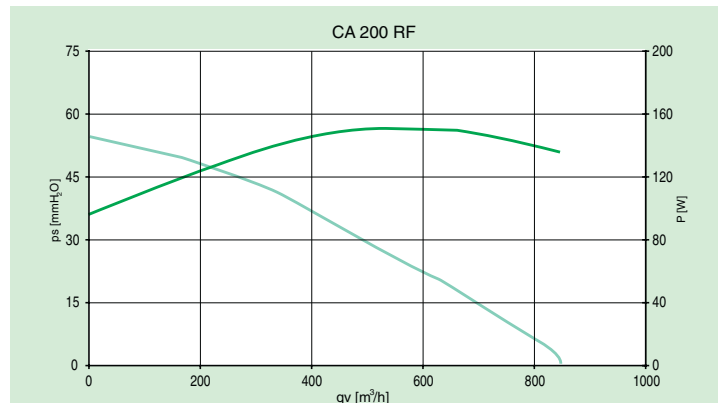
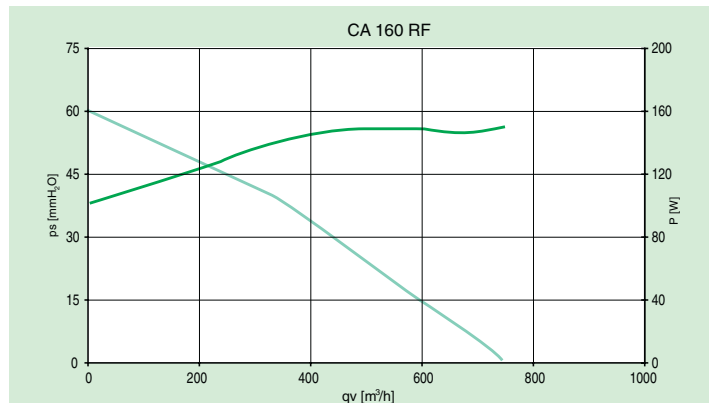
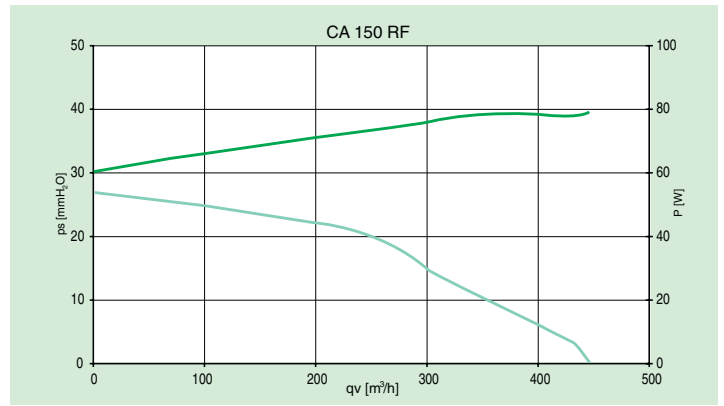
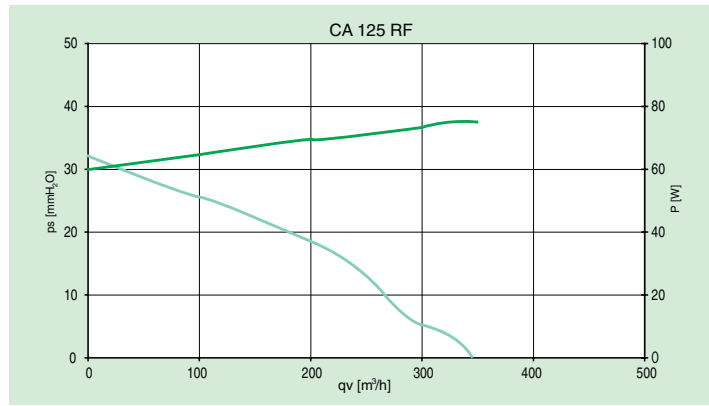

qv = delivery
 ps = static pressure
 Pw = consumption